

Electric Field Analysis and Experimental Evaluation of 400 kV Silicone Composite Insulator

M. Nageswara Rao, N. Sumathi, V. S. N. K. Chaitanya

Abstract—In electrical power system, high voltage insulators are necessary for consistent performance. All insulators are exposed to different mechanical and electrical stresses. Mechanical stresses occur due to various loads such as wind load, hardware and conductors weight. Electrical stresses are due to over voltages and operating voltages. The performance analysis of polymer insulators is an essential, as most of the electrical utility companies are employing polymer insulators for new and updated transmission lines. In this paper, electric field is analyzed for 400 kV silicone (SiR) composite insulator by COULOMB 3D software based on boundary element method. The field results are compared with EPRI reference values. Our results proved that values at critical regions are very less compared to EPRI reference values. And also experimentally 400 kV single V suspension string is evaluated as per IEC standards.

Keywords—Electric field analysis, silicone composite insulator, boundary element method, RIV, Corona.

I. INTRODUCTION

INSULATORS play a vital role in electrical power systems such as transmission lines, sub-stations and distribution systems. Insulators have gone through a rapid change in their design and the type of material used for manufacturing it. Failures after installation are minimized by these changes. In the early days, insulators are made of glass and ceramic materials. During course of development process, polymeric insulators (SiR) are developed and proposed due to its advantages compared to ceramic and glass insulators, such as hydrophobicity property, light weight, better pollution performances and easy handling, maintenance free, and considerably low of cost etc., Because of all these attributes, it is becoming more popular all over the world and common glass and ceramic insulators are replaced by polymer insulators [1], [2].

Polymeric insulators are designed by three important components. They are core, weather sheds and metal fittings as shown in Fig. 1. The core consists of axially aligned glass fibers bonded together by means of an organic resin. The end fittings are attached to core by crimping to develop the required mechanical strength. The weather sheds are used for protection of the core from moisture, UV rays, acid rains, pollution contaminations [3]. It is made from polymer materials (SiR) that have been compounded for outdoor electrical applications. It is applied over the core in various

ways to protect it and to provide maximum electrical insulation between the attachment ends [3].

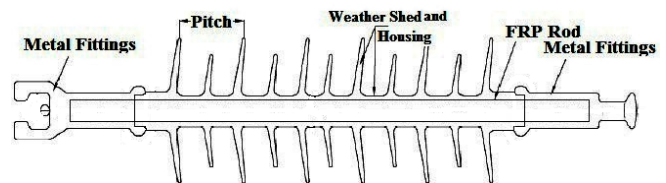

Fig. 1 Polymer Insulator [3]

For better performance of the high voltage insulators, the analysis of electric field and potential distribution along the insulator is must. In the past, laboratory experiments were performed to calculate the electric field along insulators due to the lack of efficient computational techniques. At present, there are various methods of electric field calculations. They can be categorized into experimental field analysis methods, analytical methods and numerical analysis methods [1], [2]. These methods have their own advantages and disadvantages; therefore, it is advisable to choose a suitable method as per the requirements of the analysis. Analytical methods are suitable for simple geometries. With the computing power available today, numerical methods can provide accurate electric field calculations along high voltage equipment.

Numerical methods are highly recommended for initial design stages of composite insulators used in EHV and UHV systems in order to avoid the high cost of running laboratory tests. It is divided into various methods. Among all these methods, Charge Simulation Method (CSM) is implemented by He and Gorur [1] to analyze electric field for 500 kV HVDC insulator under dry and wet conditions and results are compared with AC insulator. These results help in optimizing the grading ring and corona ring. Finite Element Method [FEM] is used by Li et al. [2] to compute electric field analysis for 500 kV AC transmission lines. Electric field and potential distribution along the surface of the polymer (SiR) insulator with and without water droplet is simulated by FEM [3]. It is proved that contaminations have no effect on potential distribution along the insulator surface. Electric field distributions are dependent on contamination conditions. Long rod insulators are modeled by Comsol multi-physics and FEM is used [4] to identify the maximum electric field stress exists on the insulator.

In this paper, COULOMB 3D software package is used based on the concept of Boundary Element Method [BEM]. This is based on boundary integral equations and the principle of weighted residuals. Calculations for the potential function

M. Nageswara Rao, N. Sumathi, and V.S.N.K. Chaitanya are Assistant Professors with the Department of Electrical and Electronics Engineering, UCEK, JNT University, Kakinada, Andhra Pradesh, India (e-mail: nagjntuk@gmail.com, ceesuma@gmail.com, chaitu824@gmail.com).

are made by calculating an equivalent source which sustains the required electric field at a given point. It is mandatory for the function to satisfy the boundary conditions. The most important feature of BEM is that it requires discretization of surfaces rather than volume. This decreases the order of the problem and also gives more accurate results.

The radio and television (RI and TVI) interference may arise due to electrical discharges run on insulators. Corona discharge on the surface of electrodes, leaky surface and spark between metal fittings are some of the electrical discharges. Among all these discharges, surface discharges can be prevented by hydrophobic treatment. This not only inhibits dry-band formation but also gives good voltage grading. The surface corona may avoid the usual power loss. The above mentioned discharges are weather dependent. Surface corona is a fair weather phenomenon; for this reason, insulator corona inception voltage is always higher than normal voltages.

In this paper, electric field analysis is done for 400 kV Silicone Composite Insulator by using COULOMB 3D software based on BEM. Radio Interference Voltage (RIV) and corona inception and extinction tests are carried out for 400 kV silicone composite insulator for single-V suspension string as per IEC and IS standards.

II. ELECTRIC FIELD ANALYSIS

A. Boundary Element Method

The software package COULOMB applies the appropriate inner product for each element, depending on the boundary conditions. A major difficulty in the integral equation approach is the integration of green function singularity. This occurs when the observation points coincide with the source points being calculated. COULOMB handles this singularity by further dividing the singularity and using different transformations in order to remove them. For the analysis of electric field in insulators, Boundary Element Analysis is an efficient method. It gives high accuracy while decreasing the dimensionality of the problem by one. Generally, insulators are rotational symmetric. COULOMB makes use of this advantage by considering only angular sections of the entire geometry for calculations. This reduces the computation time significantly. There are also means to check the accuracy of results.

B. Assigning Material Properties

To design the insulator model, basic dimensions like length of the insulator, creepage distance and dry arcing distance are required. They need to meet with IEC and IS standards. Insulator dimensions are measured as per IEC 61109 [5] and are shown in Table I.

TABLE I
DIMENSIONS OF 400KV SILICONE COMPOSITE INSULATOR

Voltage Rating (KV)	Sectional Length (mm)	Dry Arcing Distance (mm)	Creepage Distance (mm)	Specific Mechanical Load (KN)
420	3335	3060	13020	90

The numerical analysis is carried out on a 3.16 GHz processor, 4 GB RAM. Relevant material properties are assigned for different parts of the model. Table II lists basic properties like relative permittivity and thermal conductivity of the materials used for modeling. Material properties assigned for the model are shown in Fig. 2.

TABLE II
MATERIAL AND THEIR PROPERTIES USED IN MODELING

Material	Relative permittivity	Thermal conductivity (Mho/m)
Silicone	3	1e-017
Fiber Glass	5	1e-012
Steel	1	1670000

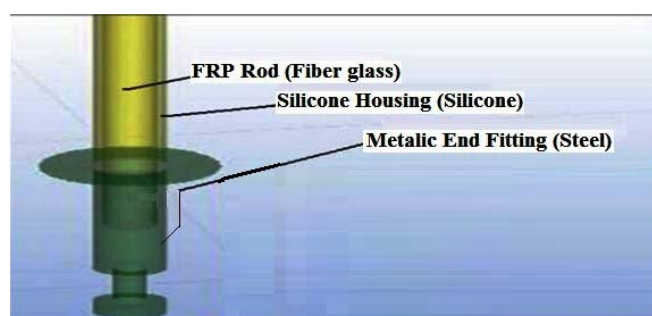

Fig. 2 Assigning material properties to different parts of Composite Insulator in COULOMB

C. Assigning Boundary Conditions

After assigning material properties, rated line-to-ground voltage (i.e., $420/\sqrt{3}=242$ kV) is applied to the high voltage end fitting and zero (0 V) volts to the grounded end fitting of the composite insulator. The next step is to define the angular periodic sections. For the ease in construction of the model and reduction in the computation time, only angular sections of the rotational symmetric model are considered. It is essential to specify the section angle and also the number of sections required to complete one insulator. The number of sections is given by 360° divided by the angle of the section considered.

D. Assigning Boundary Elements

The boundaries in the model need to be discretized into individual sections, referred to as boundary elements. The distribution, number and shape of these elements are the key factors that determine the accuracy of the solution. BEM generally uses 2D elements for analysis purpose. In this paper, 2D triangular elements were chosen as it is relatively simple to assign 2D triangular elements to any surface when compared to 2D quadrilateral elements which can be assigned to only four sided surfaces. 2D view and 2D triangular elements of the insulator model are shown in Fig. 3.

The accuracy of the results obtained gets better with increasing the number of the elements assigned. In hindsight, this might cause an unreasonable increase in the computation time. Therefore, a trade-off between accuracy and computation time has to be made. Initial runs were carried out in order to establish the optimum number of 2D triangular elements keeping both these factors in mind.

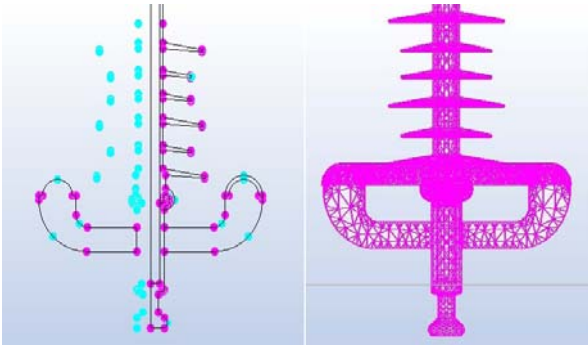

Fig. 3 2D view and 2D Triangular boundary elements assigned along Silicone Composite Insulator in COULOMB

E. Electric Field Analysis Results

The following steps are carried out in the process of computing the electric field distribution:

- i. Identification of regions of critical Importance.
- ii. Modeling of insulator using BEM.
- iii. Analysis of electric fields at critical regions.

i. Identification of Regions of Critical Importance:

The regions with maximum electric field inside the different dielectric materials of the insulator and around the insulator have to be identified to check the design of the insulator. The regions of critical importance are:

- 1. Inside the FRP (fiber reinforced polymer)
- 2. Inside the SiR (silicone rubber)
- 3. At triple point junction
- 4. On surface of SiR

ii. Modeling of Insulator Using BEM

The HV Terminal along with the grading ring is energized with 242 kV ($420 \text{ kV}/\sqrt{3}$) and LV terminal at 0 V. The electric field is computed using electrostatic 3D COULOMB software. Insulator model used to analyze Boundary Element Method is shown in Fig. 4.

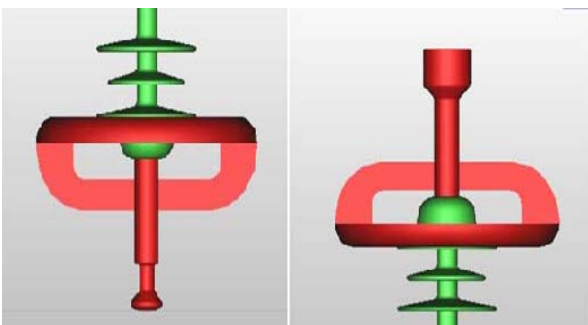

Fig. 4 Insulator used for Boundary Element Analysis (end fittings)

iii. Analysis of Electric Fields at Critical Regions

The voltage distribution and electric field distribution in and around the insulator is calculated using COULOMB 3D software. Fig. 5 shows voltage distribution along FRP. Fig. 6 shows voltage distribution along SiR.

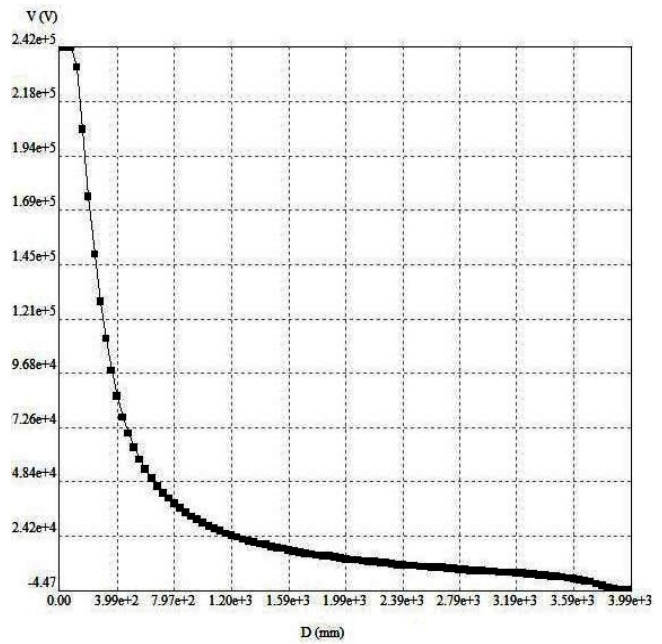

Fig. 5 Voltage Distribution along FRP

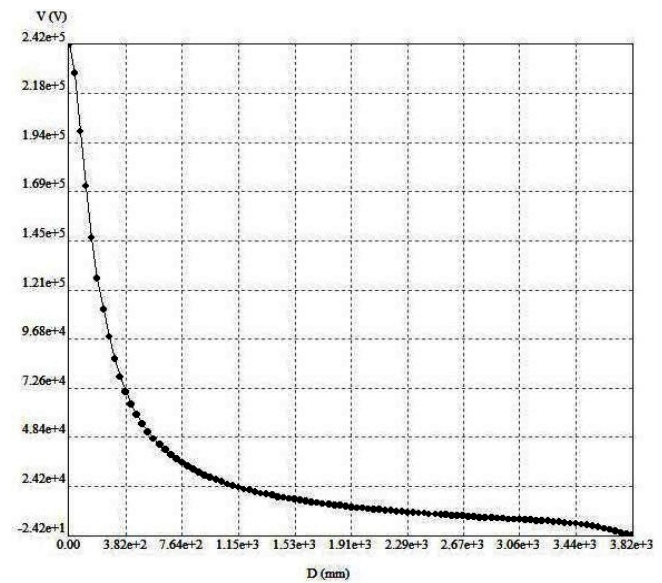

Fig. 6 Voltage Distribution along SiR

Electric fields inside FRP and inside SiR are shown in Figs. 7 and 8.

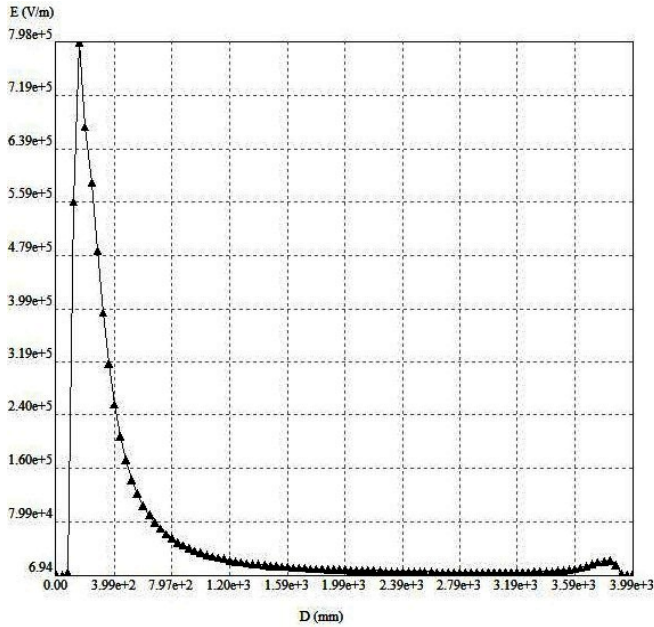

Fig. 7 Electric field inside FRP

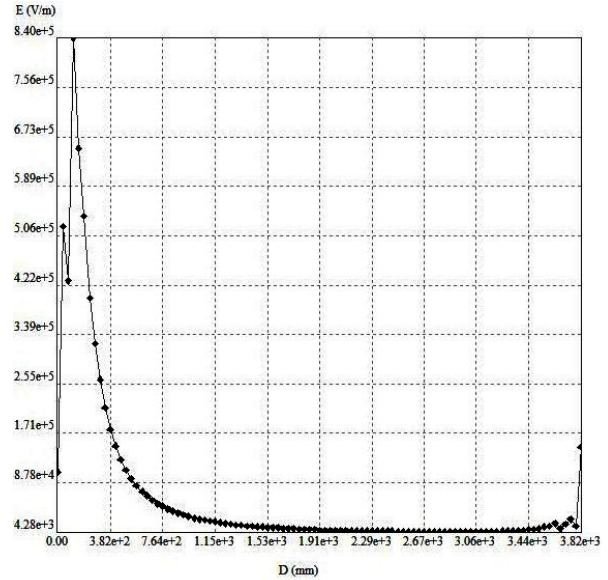

Fig. 8 Electric field inside SiR

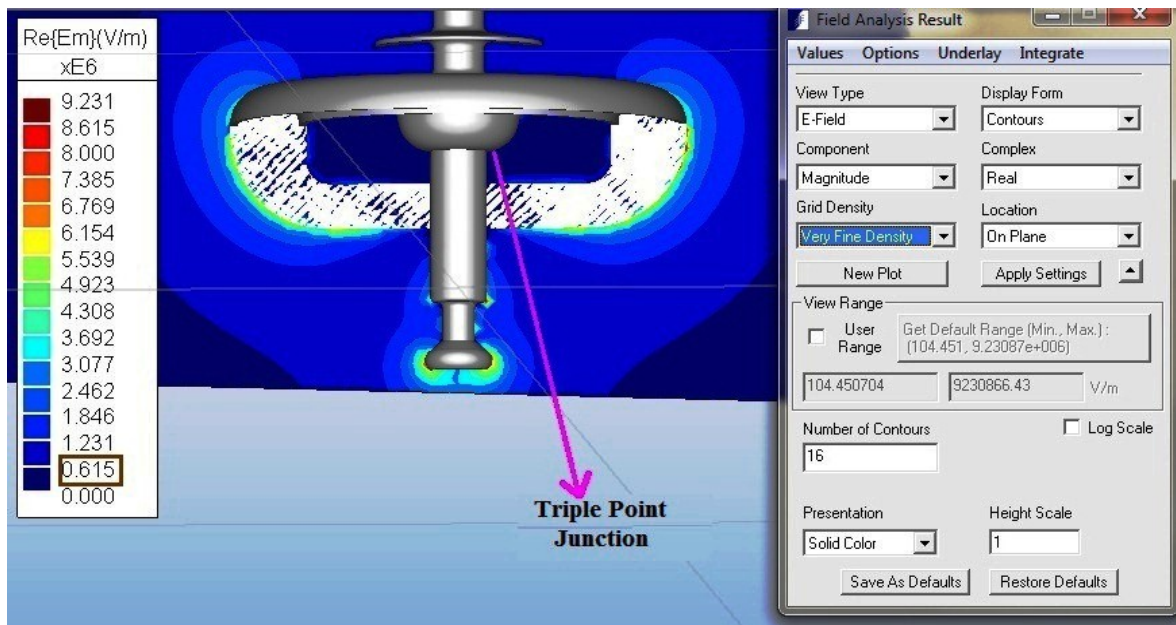

Fig. 9 Electric Field at Triple Point Junction

The maximum electric field value occurs at the triple point. Triple point is a point where, insulating housing material, energized end fitting and air are located. When we apply more voltage, stresses will be higher at that point. Electric field at triple point junction is shown in Fig. 9.

Electric field on the surface of the SiR is shown in Fig.10. The field results of maximum electric field Intensities at the critical areas (kV/mm) are tabulated in Table III. The results are compared with EPRI reference values [6]-[8]. Allowable maximum field intensities at critical regions of the insulator are given in EPRI. By using BEM, the field intensities at

critical regions are very less when compared with EPRI reference values.

TABLE III
 ELECTRIC FIELD ANALYSIS RESULTS

S.No	Critical Regions of the Insulator	Observed Values (kV/mm)	Reference Values (kV/mm)
a	Inside FRP	0.798	3
b	Inside Silicone Rubber(SiR)	0.84	3
c	At Triple Point Junction	0.615	1.5
d	On Surface of SiR	0.302	0.45

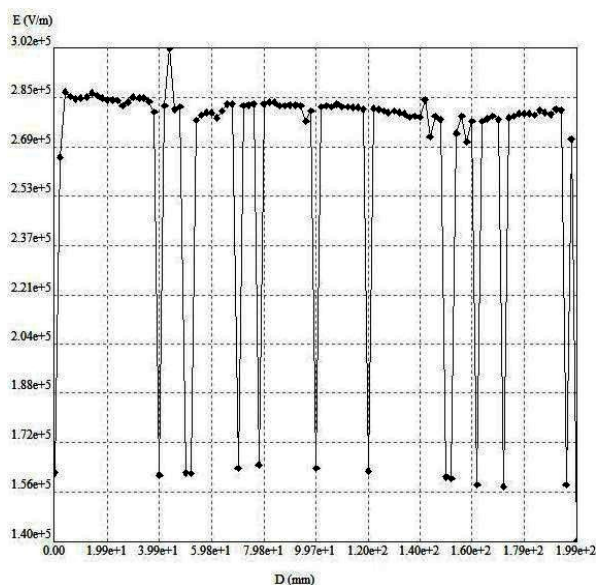

Fig. 10 Electric field on the Surface of SiR

III. EXPERIMENTAL ANALYSIS

A. Test Sample

Based on the purpose of testing, the tests to be performed on polymeric insulator are classified in to four categories as design tests, type tests, sample and routine tests. Type tests are intended to verify the main characteristics of the insulators, which depend mainly on the shape and size.

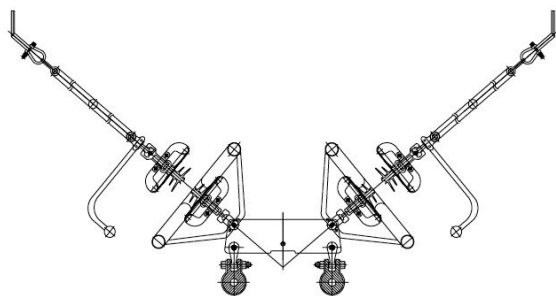

Fig. 11 Single-V Suspension String

Interference with radio and television (RI and TVI) may arise when electrical discharges run on insulators and inject high-frequency currents into associated conductors, which radiate electromagnetic waves. On insulator string, RIV and Corona effects will be much higher. In this paper, RIV test and Corona inception and extinction tests are performed on 400 kV Single-V Suspension string as shown in Fig. 11. Insulator dimensions are as per Table I. Specific creepage distance of the insulator is 31 mm/kV (very heavy polluted).

B. RIV Test

i. Test Arrangement

Samples are mounted as per Fig. 11. Before starting the test, all string hardware bolts need to be tightened. In this paper, twin-moose conductors are used for testing. After string is

mounted in suspension mode, test sample is energized as per the circuit shown in Fig. 12.

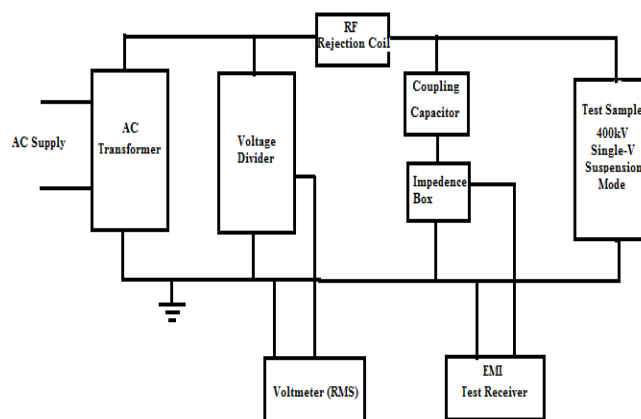

Fig. 12 RIV Test Arrangement

ii. Test Procedure

Complete Insulator String along with complete hardware fittings has a measuring frequency of 1 MHz subjected to 50 Hz AC voltage of 305 kV line to ground under dry condition. Test is conducted as per IEC 60437 [9]. As per specification 110% of the test voltage (i.e. 335.5 kV) is maintained for five minutes from this point the voltage is gradually decreased up to 30% of the test voltage and respective RIV level is noted. And from 30% to 110% of the test voltage is gradually increased and RIV level is noted. Final RIV level values are tabulated taking in the decreasing test voltage gradually from 110% to 30% [9]. Test results are tabulated in Table IV.

TABLE IV
RIV TEST RESULTS

Test Voltage kV (RMS)	RIV Level (μV)
335.5	758
305	691
274.5	631
244	616
213.5	562
183	524
152.5	457
122	426
91.5	375

Characteristics are drawn between test voltage and RIV level as shown in Fig. 13. As per standard at 100% of the test voltage RIV level should not be more than 1000 μV . The test results show that at 305 kV (100%), RIV level is 691 μV . Correction factor is applied as per IEC 60060-1 and 60060-2 [10]-[11].

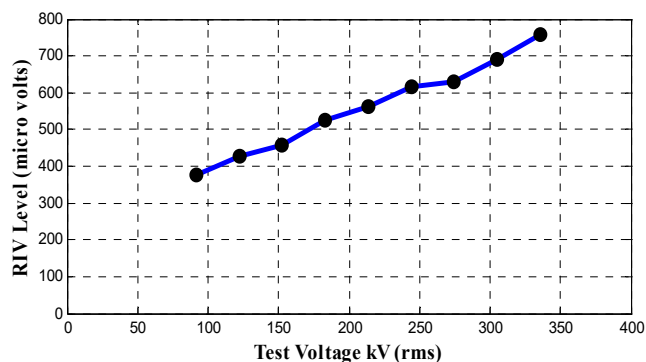

Fig. 13 RIV Characteristics

C. Corona Inception and Extinction Test

i. Test Arrangement

Samples are mounted as per Fig. 11. After string is mounted in suspension mode, test sample is connected across voltage divider as shown in Fig. 14.

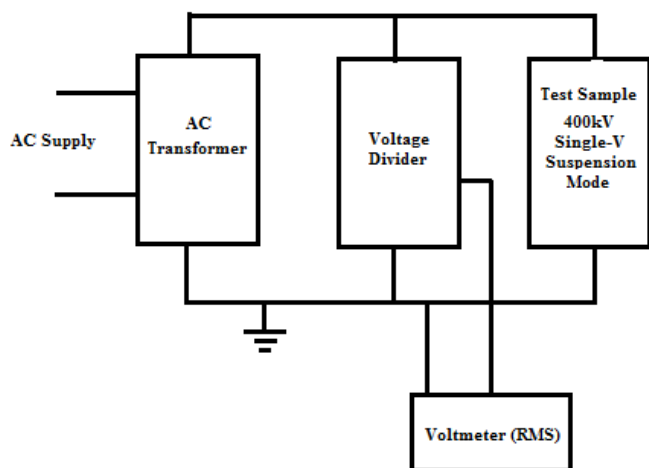

Fig. 14 Corona Test Arrangement

ii. Test Procedure

The Sample assembly subjected to power frequency voltage. Under dry condition corona is not present at 266 kV (rms). As per IS731 corona should not be present on any part of the sample and string at 266 kV [12]. The test results are shown in Table V.

Corona inception Voltage kV (rms)	Corona extinction Voltage kV (rms)
395	384

IV. CONCLUSION

This paper is aimed to analyze electric field for 400 kV silicone composite insulator used in transmission systems with the aid of BEM by COULOMB 3D software. This method can be used to investigate the various factors that affect the electric field and voltage distribution along composite insulator. This tool is extremely useful in designing EHV and

UHV composite insulators. Among various numerical electric field analysis techniques, BEM is chosen to carry out this work. Designing included establishing optimum number of boundary element conditions in order to obtain an accurate solution keeping the computation time reasonable. For 400 kV silicone composite insulator with corona ring at both HV and ground ends, Electric Field Analysis (EFA) is performed by COULOMB 3D software. The corresponding simulated EFA values are less when compared to reference EPRI values. RIV and corona inception and extinction tests are carried out for 400 kV silicone composite insulator under single-V suspension string with twin-moose conductors. RIV level at 100% of voltage (305 kV) is 691 μ V. Corona is not present at 266 kV (rms). Corona Inception and extinction voltages are 395 kV (rms) and 384 kV (rms).

ACKNOWLEDGMENT

We acknowledge our gratitude to Deccan Enterprises Limited for their support in completion of this work.

REFERENCES

- [1] Jiahong He, Ravi S. Gorur "Charge Simulation Based Electric Field Analysis of Composite Insulators for HVDC Lines," *IEEE Transactions on Dielectrics and Electrical Insulation*, vol. 21, no. 6, pp.2541-2548, Dec. 2014.
- [2] Jing Li, Zongren Peng, Yong Feng, Xiaoyong Fu, Tianxi Xie "Electric Field Calculation and Grading Ring Optimization of Composite Insulator for 500kV AC Transmission Lines," *International Conference on Solid Dielectrics, Potsdam, Germany*, pp.1-4, July. 2010.
- [3] B. Marungsri, W. Onchantuek, A. Oonsivilai, T. Kulworawanichpong "Analysis of Electric Field and Potential Distribution along Surface of Silicone Rubber Insulators under various contamination conditions using Finite Element Method," *International Journal of Electrical and Computer Engineering*, pp.156-166, March. 2010.
- [4] Rahul Krishnan, Subhajit Samanta, Sudha R&K Govardhan "Electric Field Analysis of High Voltage Insulators," *International Journal of Computer Science and Informatics*, ISSN:2231-5292, vol. 1, Iss.4, pp.31-35, 2012.
- [5] IEC Standard-61009 "Insulators for Overhead Lines Composite Suspension and Tension Insulators for A.C. Overhead Lines with a Nominal Voltage Greater Than 1 000 V Definitions, Test Methods and Acceptance Criteria", 2008.
- [6] Field Guide: "Corona rings for polymer insulators-selection, inspection and assessment 1008741", EPRI. Pala Alto, CA, Mar.2005.
- [7] Field Guide: "visual inspection of NCI: Ricision 1", EPRI. Pala Alto, CA 1008739, May.2004.
- [8] Field Guide: "Corona and Arcing Inspection of transmission lines", EPRI. Pala Alto, CA 1001910, Oct.2001.
- [9] IEC Standard-60437 "Radio Interference test on High Voltage Insulators", 2005.
- [10] IEC Standard-60060-1 "High voltage Test Techniques Part-1 General Definitions and Test Requirements", 2010.
- [11] IEC Standard-60060-2 "High voltage Test Techniques Part-2 Measuring Systems", 2010.
- [12] IS Standard-731 "Specification for Porcelain Insulators for Overhead Power Lines With A Nominal Voltage Greater Than 1 000 V", 2001.